

FEATURE

- Ceramic brazing sealed technology guarantees no risk of arc leaking and ensures no fire or explosion
- Filled with gas (mostly hydrogen) to minimize contact oxidation and damage from arcing; contact resistance is low and stable; contact part can meet IP67 protection level.
- current 100A continuously at 85°C
- Insulation resistance is 1000MΩ(1000Vd.c.), and dielectric strength between the coil and contacts is 4.0kV, which meets the requirements of IEC 60664-1.



APPLICATIONS

New energy vehicle , Charging point, Photovoltaic ,
Energy storage , Industrial power

CONTACT DATA

Contact Arrangement	1 Form A
Contact Resistance	≤75 mV at 100 A
Rated Load Current	100 A (@ 35 mm ² wire)
Rated Switching Voltage	450 Vd.c. or 750 Vd.c.
Rated Switching Power	45 kW(450 Vd.c.) or 75kW(750 Vd.c.)
Min. Applicable Load	6 Vd.c., 1 A
Max. Switching Voltage	750 Vd.c.
Max. Switching Power	75kW(750 Vd.c.)
Max. Breaking Current	1000 A (300 Vd.c.) 1op

CHARACTERISTICS

Dielectric strength	Between coil & contacts	3000 Va.c 1 min
	Between open contacts	4000 Va.c 1 min
Insulation resistance	1000 MΩ at 1000 Vd.c.	
Operate time (at nomi. volt.)	≤30 ms	
Release time (at nomi. volt.)	≤10 ms	
Vibration resistance	10Hz~500Hz, 49 m/s ²	
Shock resistance	Functional	196 m/s ²
	Destructive	490 m/s ²
Ambient temperature	-40°C~85°C	
Humidity	5% RH ~85% RH	
Termination	M4 Screw terminal male/ M4 Screw terminal male+ Busbar	
Mounting	M5 Screw	
Unit weight	Approx.280g	
Outline Dimensions	76.0mmx36.0mmx66.8mm	

Notes: Above is the initial vale in the room temperature

COIL

Coil power W	Nominal Voltage Vd.c.	Pick-up Voltage Vd.c.	Drop-out Voltage Vd.c.
5.5	12	≤9	≥1
	24	≤18	≥2

Notes: The values above are conservative values within the temperature range(-40°C to 85°C),

ENDURANCE

Project		450 Vd.c.	750 Vd.c.
Electrical Endurance	Capacitive Load	Making: 2.5×10 ⁴ ops (22.5Vd.c., τ=1ms, Impact 400A, Steady100A)	Making: 1×10 ⁴ ops (37.5Vd.c., τ=1ms, Impact 400A, Steady 100A)
		Switching: 3000ops (450 Vd.c. ,100A)	Switching: 1000ops (750 Vd.c. ,100A)
	Resistive Load	Switching: 1500ops (450Vd.c. ,-100A)	Switching: 300ops (750Vd.c. ,-100A)
		Switching: 1.0×10 ⁵ ops (450 Vd.c. ,20A)	/
Current Endurance	Breaking:1op (300Vd.c. ,1000A)	/	/
		100A, Cont.	
		150A, 2.0h	
		200A, 10min	
		300A, 2min	
		400A,30s	
	600A, 10s		
	900A, 4s		
Mechanical endurance	2×10 ⁵ ops, on-off ratio:0.6s:5.4s		

Notes: (1) Until special statement, the temperature of electrical endurance is at 23°Cand the on-off ratio is 0.6s:5.4s.

ORDERING INFORMATION

	CHEV	-1	12	P	100	-1	L	1	, xxx
Product Series:	CHEV								
Contact Arrangement:	1:1 Form A								
Nominal Voltage:	12:12Vd.c. 24:24Vd.c.								
Sub-series:	P: P Series								
Load Current:	100:100A								
Load Voltage:	1: 450Vd.c. 2: 750Vd.c.								
Coil Termination	L:Wire								
Termination	1:Screw Terminal Female 2: Screw Terminal Female+Busbar								
Extra numbers or letters:	Blank or Other Customer Requirements								

Notes: The customer special requirement express as special code after evaluating by Churod.

OUTLINE DIMENSIONS

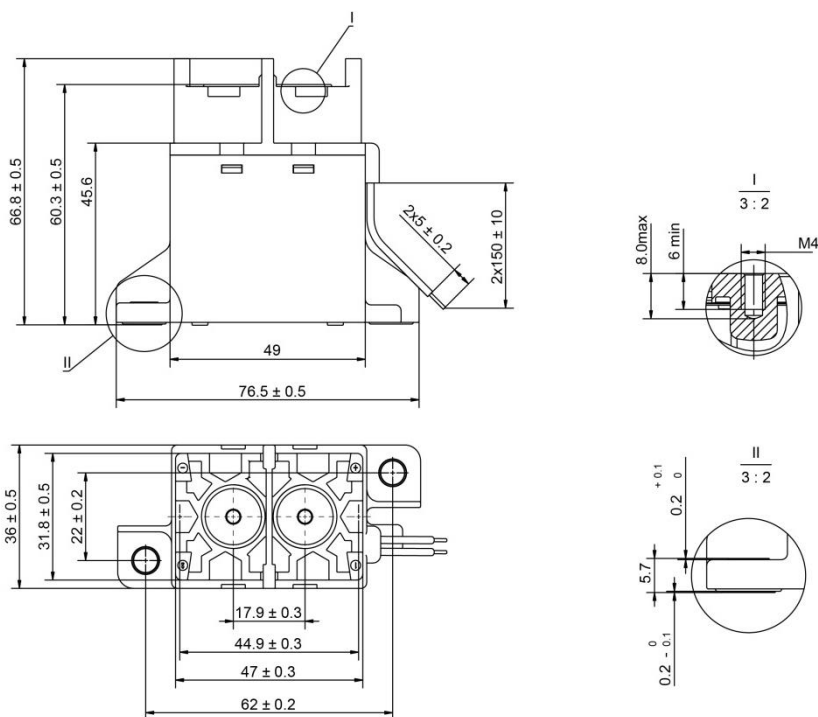

OUTLINE DIMENSIONS

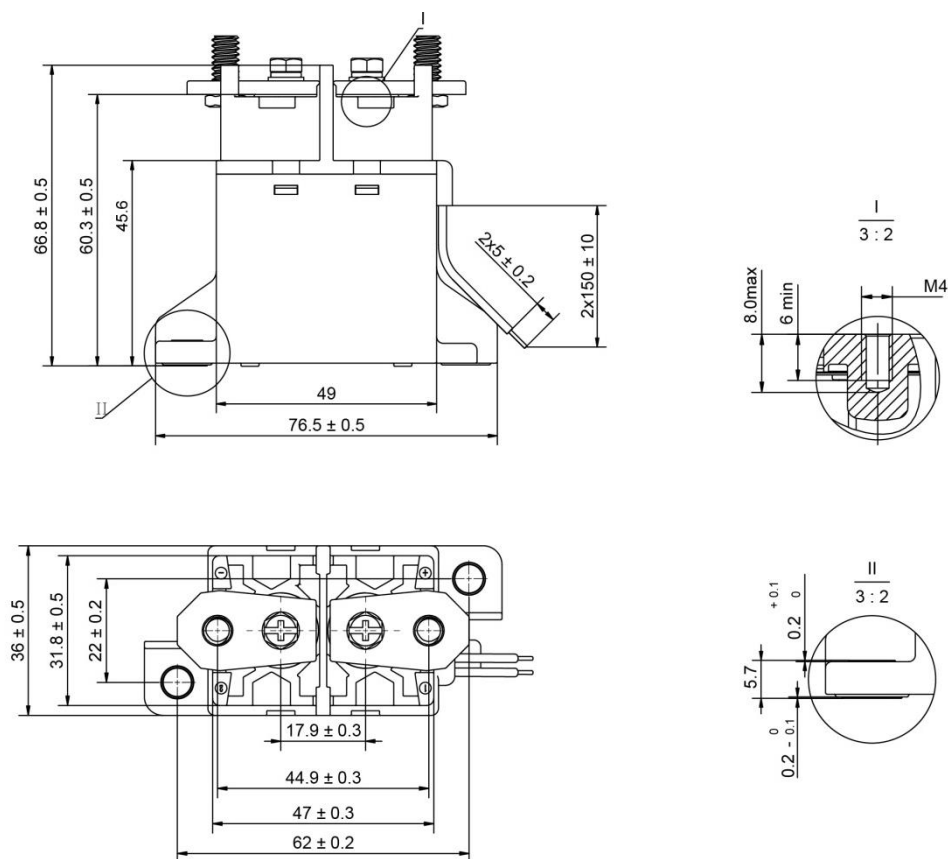

Remark: in case of no tolerance shown in outline dimension: outline dimension $\leq 10\text{mm}$: tolerance should be $\pm 0.3\text{mm}$, outline dimension $> 10\text{mm}$ and $\leq 50\text{mm}$, tolerance should be $\pm 0.5\text{mm}$, outline dimension $> 50\text{mm}$, tolerance should be $\pm 0.8\text{mm}$.

INSTALLATION HOLE SIZE , WIRING DIAGRAM

Installation Hole

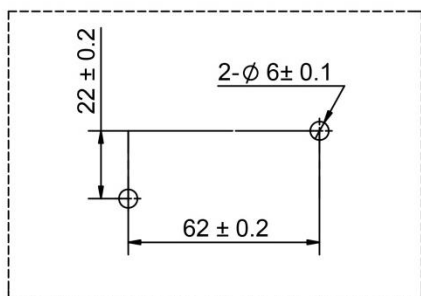

Wiring Diagram

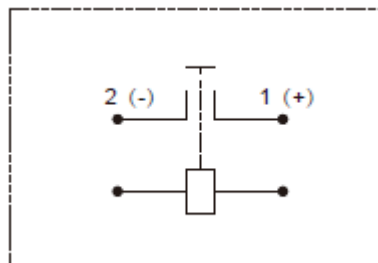

Note: The load has polarity and The coil has no polarity

INSTALLATION INFORMATION

Load Terminal Installation				
Installation Mode	Selection Screw	Torque	Copper Busbar Diameter	Copper Busbar Thickness
M4 Screw	M4×11 Combined Bolt	2N·m ~3N·m	φ 4.0 ~4.5 mm	2.0 ~3.0 mm
M6 Nut	/	6N·m ~8N·m	φ 6.0 ~6.5 mm	2.0 ~3.0 mm

Relay Installation	
Installation Mode	Torque
M5 Screw	3N·m ~4N·m

Combined Bolt Drawing
(Optional)

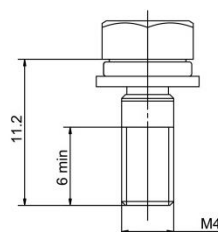

Note:

- In order to prevent loosening, please use the washer when installing the relay.
- Please avoid grease and other foreign matter in the terminal, please use the connecting wire with a cross section area $\geq 35\text{mm}^2$, or they may cause abnormal heating in the terminal part.

DISCLAIMER

The specification is for reference only. See to "Terminology and Guidelines" for more information. Specifications subject to change within notice. We could not evaluate all the performance and all the parameters for every possible application. Thus the user should be in a right position to choose the suitable product for their own application. If there is any query. Please contact Churod for the technical service. However, it is the user's responsibility to determine which product should be used only.