

FEATURES

- 60A switching capability
- 1Form A and 1 Form C contact arrangement
- Multiple installation methods
- Multiple operating voltage
- Comply with RoHS and ELV instruction



APPLICATION

Rear window defogger/Battery breaker/Oil pump control
 Automobile air conditioner/Cooling fan control
 Fog lamp/Headlamp control
 ABS

COIL PARAMETER

Coil voltage	12VDC/24VDC	
Coil power	CHAF6-D	1.6W
	CHAF6-D1	1.6W
	CHAF6-D2	1.6W
	CHAF6-R	1.8W

COIL DATA @23°C

CHAF6-D/CHAF6-D1/CHAF6-D2						
Nominal coil voltage (VDC)	Nominal Current (mA)	Coil Resistance ($\Omega \pm 10\%$)	Parallel Resistance ($\Omega \pm 5\%$)	Equivalent Resistance (Ω)	Operate Voltage (VDC Max.)	Release Voltage (VDC Min.)
12	133.33	90	—	—	8.4	1.2
24	66.67	360	—	—	16.8	2.4

CHAF6-R						
Nominal coil voltage (VDC)	Nominal Current (mA)	Coil Resistance ($\Omega \pm 10\%$)	Parallel Resistance ($\Omega \pm 5\%$)	Equivalent Resistance (Ω)	Operate Voltage (VDC Max.)	Release Voltage (VDC Min.)
12	150.94	90	680	79.5	8.4	1.2
24	75.57	360	2700	317.6	16.8	2.4

CONTACT DATA

Contact arrangement	1 Form A, 1 Form C
Contact material	Silver Alloy
Initial contact resistance	40mV Type, 200mV Max (at 10A)
Max. switching voltage	30VDC
Max. switching current	60A
Max. switching power	840W
Contact rating (Resistive Load)	NO/NC: 60A/30A 14VDC
Mechanical endurance	10,000,000 ops Min.(no load)
Electrical endurance	100,000 ops Min.(rated load)
Minimum load (reference value)	1A@6VDC

CHARACTERISTICS

Operate voltage	70% of nominal voltage or less	
Release voltage	10% of nominal voltage or more	
Operate time(At nominal voltage)	10ms max.	
Release time(At nominal voltage)	10ms max.	
Insulation resistance	100M Ω min. (at 500 VDC)	
Dielectric strength	Between coil and contacts	≥ 500 VAC, 50/60Hz (1 min)
	Between open contacts	≥ 500 VAC, 50/60Hz (1 min)
Vibration resistance	Destruction	10Hz~ 55Hz., 1.5mm double amplitude
	Malfunction	10Hz~ 55Hz., 1.5mm double amplitude
Shock resistance	Destruction	1,000m/S ² (100G Min.)
	Malfunction	100m/S ² (10G Min.)
Ambient temperature	-40~ +125°C (without icing or condensation)	
Ambient humidity	20%~85% RH	
Terminal	QC terminals	
	PCB terminals	
Enclosure (94V-0 Flammability Ratings)	V: Vented(Dust-protected, RTI)	
	S: Sealed(Wash-tight, RTIII)	
Weight	Approx. 26g	

ORDERING INFORMATION

	CHAF6	P	-V	-1	12	D	A	2	,000
1.Product Family									
2.Terminal (Blank): QC Terminal P: PCB Terminal									
3.Enclosure V: Vented(Dust-protected, RTI) S: Sealed(Wash-tight, RTIII)									
4.Number of Poles 1: 1 pole									
5.Rated Coil Voltage 12, 24VDC									
6.Parallel component D: Without parallel component R: With resistor D1: With parallel diode(Anode on 86#) D2: With parallel diode(Anode on 85#)									
7.Contact Arrangement A: Form A(SPST) C: Form C(SPDT)									
8.Contact Material 2: AgSnO ₂									
9.Additional numbers and /or letters 000-999, AAA-ZZZ, aaa-zzz or blank, which does not represent electrical changes, only for specific customer requirements									

OUTLINE DIMENSION

QC Terminal

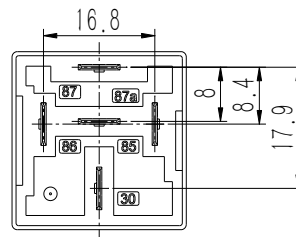
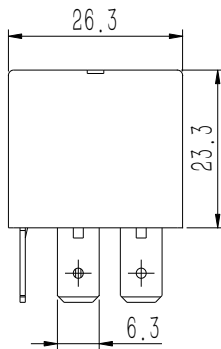
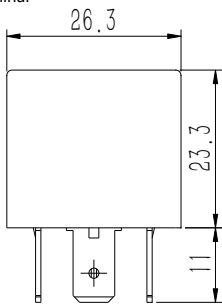

PCB Terminal

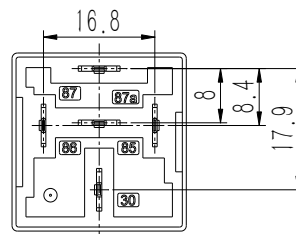
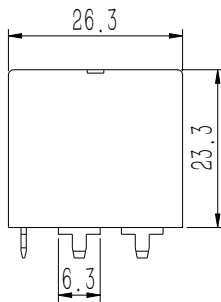
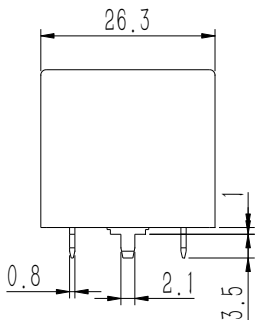

Remarks:

- The reference tolerance in outline dimension:
 - outline dimension ≤ 1 mm, reference tolerance is ± 0.2 mm;
 - outline dimension > 1 mm and ≤ 5 mm, reference tolerance is ± 0.3 mm;
 - outline dimension > 5 mm, reference tolerance is ± 0.5 mm.
- The reference tolerance for PC Board layout is ± 0.1 mm.

WIRING DIAGRAMS (BOTTOM VIEWS)

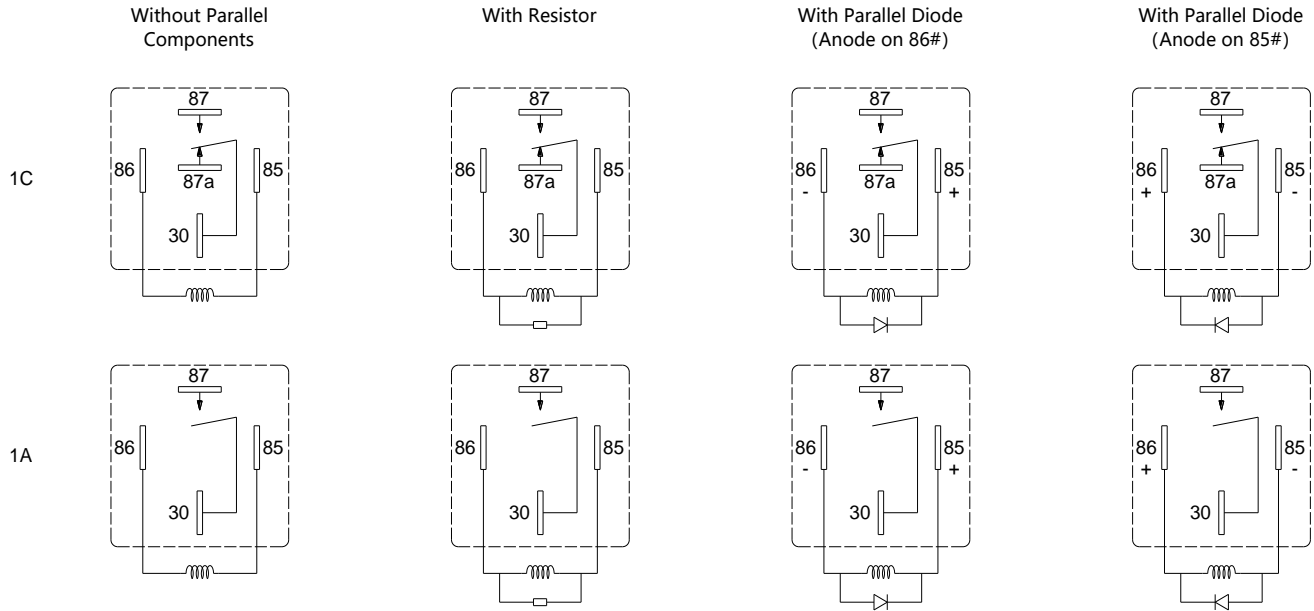

Reference Data

Maximum Load Range

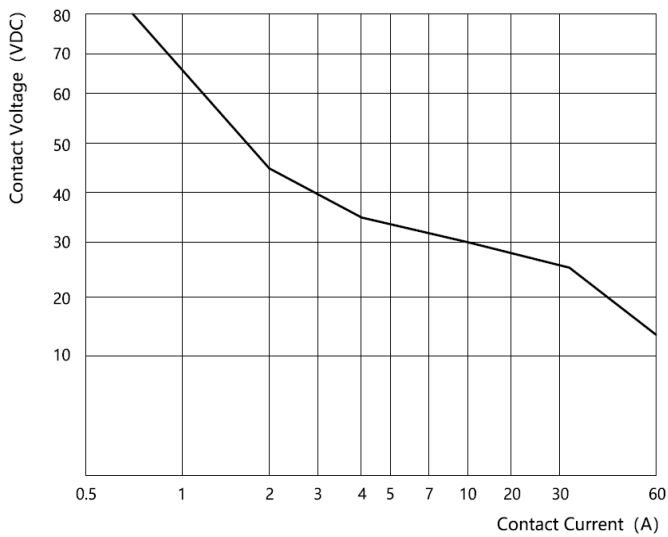

Ambient Temperature Curve of the Electrical Endurance Test



Disclaimer:

The specification is for reference only, if you need more detail information, please contact Churod. We could not evaluate all the performance and all parameters for every possible application. And the user should be in a right position to choose the suitable product for their own application. If there is any new need, please contact Churod for the technical service.

[Http://www.churod.com](http://www.churod.com)

2021 Rev.01 Churod Electronics Co., Ltd.